

NOTE: TWO (2) CONNECTING PIN HOLES @ HIGH END & ONE (1) @ *LOW END

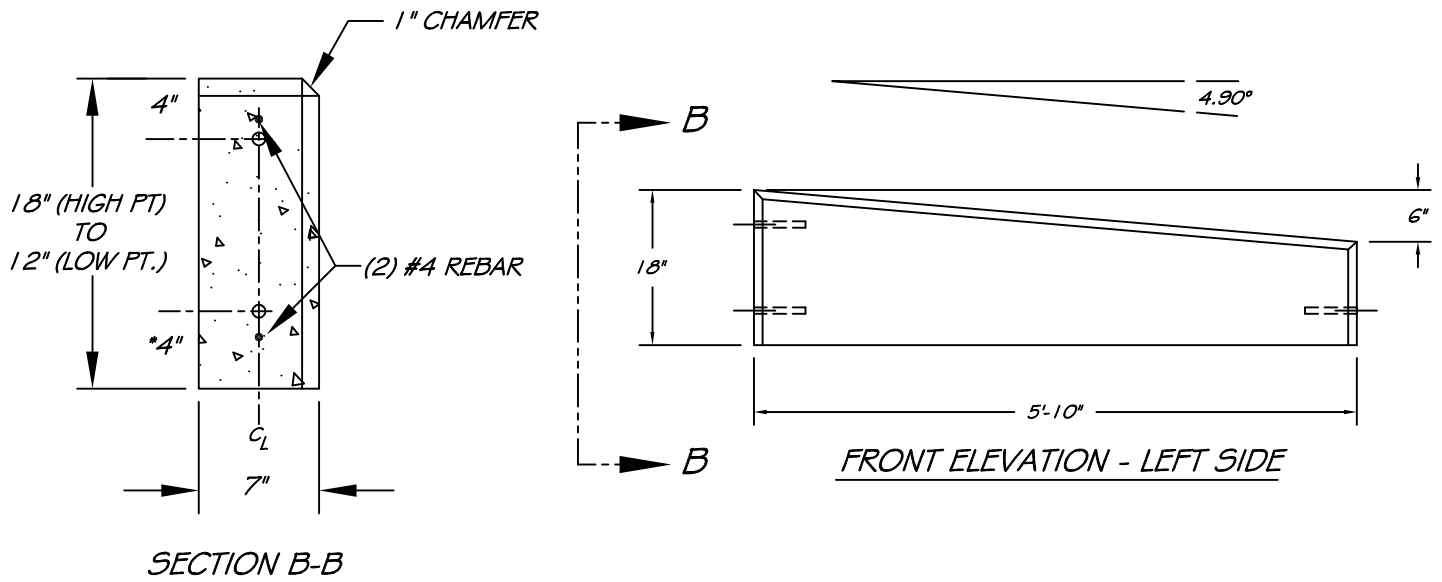

3' AND 8' TIP DOWN LENGTHS ALSO AVAILABLE - SIMILAR

DESIGN NOTES

1. CONCRETE: 5,000 PSI @ 28 DAYS
2. CEMENT: PORTLAND CEMENT TYPE III PER ASTM C 150
3. RADIUS TIPDOWN TRANSITIONS NOT AVAILABLE
3. APPROX. WEIGHT 650 lbs.

PRECAST STREET CURB - 6' TIP DOWN SECTION

CRB-6TD

www.georgerobertsco.com

George R. Roberts Co.
Precast Concrete Products

192 Biddeford Road Phone 207-324-6571
Alfred, Maine 04002 Fax 207-324-8533